



ESPRIT Production Machining

ESPRIT delivers powerful programming, accurate simulation, and machine-optimized G-code for any class of CNC machine tool including horizontal, vertical, and gantry machines.

As a full-spectrum solution for high value-added parts and processes, and demanding machining applications, ESPRIT is the right choice for any industrial application, from job shop work to large-scale heavy equipment manufacturing. With ESPRIT, production machining includes the ability to combine milling, turning, and probing cycles into one program to utilize the full capability of the machine tool and maximize shop productivity.

Production Machining

Natural Workflow

From CAD design to machine-optimized G-code, ESPRIT provides a natural workflow throughout. Job shops benefit from the ability to read CAD files in virtually any format, while manufacturers see improved workflow integration as ESPRIT reads native CAD data from the leading design systems. ESPRIT will import CAD feature tree (FX) and the product manufacturing information (PMI) along with the part geometry to give the programmer a complete definition of the part, without the need for secondary documentation. Output from the system includes edit-free G-code that may include sub programs for readability and repeatability, along with optional tooling and operation reports for use on the shop floor.

Program One Part, Machine Many

ESPRIT provides tremendous power for multi-part machining, different parts or different sides of the same part, using different workholding. With its part view, ESPRIT makes it easy to develop and review the process plan to machine a given part, while the machine view visualizes how one or more instances of one or more parts will be cut on the machine. The result is simplified programming with complete understanding of the actual on-machine process. With the freedom to program milling, turning, or probing cycles on a “milling” machine, ESPRIT’s Modeless Programming™ lets the programmer take full advantage of the CNC. In the case of last-minute changes to the setup, number of parts to be machined, or machine choice, ESPRIT automatically updates the program for the new machine configuration.

Programming with a Digital Twin

To provide the knowledge that drives its most advanced and beneficial features, ESPRIT uses a digital twin of the CNC along with the part setup and tooling. Setting up the machine digitally in ESPRIT, with realistic tool assemblies and workholding as done in the shop, gives ESPRIT an awareness of the real manufacturing environment. This Machine Awareness helps CAM programmers make better choices and see improved machine performance. The programming is simplified and many tasks are automated such as link generation, cycle time optimization, machine simulation, process verification, and collision detection. Process verification includes support for set up changes and dynamic fixtures with axis motion, travel limits, and stop on contact.

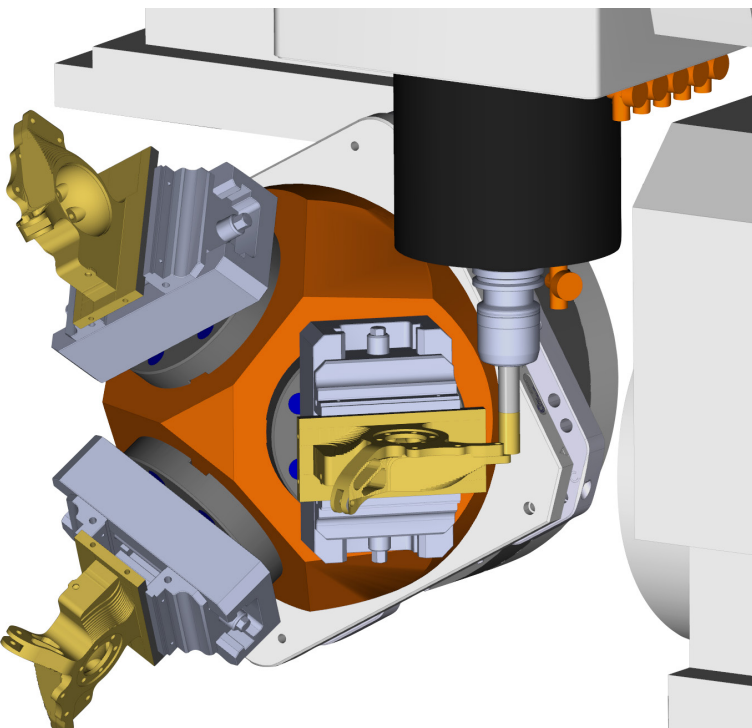

Optimized Production

ESPRIT automatically optimizes cycle times by minimizing tool changes, axis rotations, and machine travel, all while taking into consideration dependencies between operations and setups. This produces highly efficient part programs and maximum machine utilization. Dependencies may be inherent such as roughing before finishing or those added by the programmer due to unique requirements for a given part. Other considerations for optimization include automatic detection of setup changes such as part flip, eject, and transfer. The use of common cutting tools and operations across multiple workpieces is also automatically consolidated.

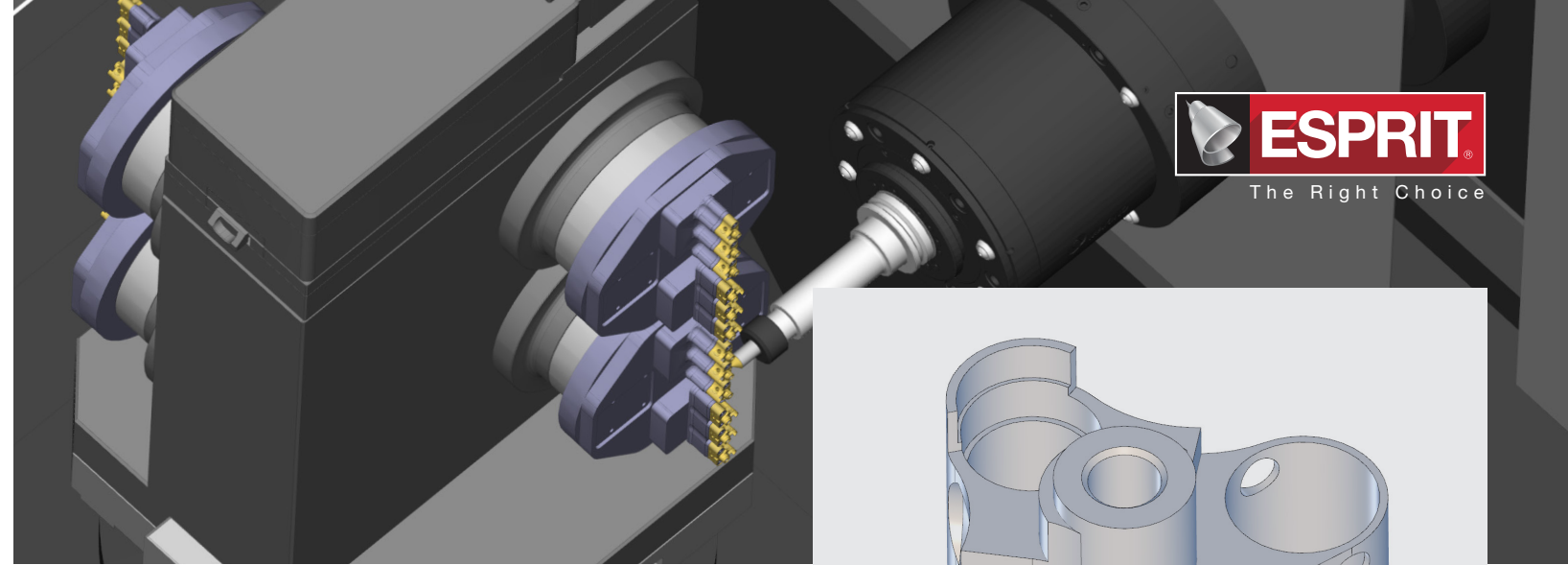

Intelligent Work Offsets

ESPRIT provides comprehensive, native support for a wide range of work offsets, mapping the machine’s coordinate system to the different workpiece coordinate systems commonly needed in a production machining environment. This greatly simplifies dealing with variances in workpiece size and positioning, complex fixturing, multiple parts on a tombstone, multi-sided 5-axis machining, and more. Once the work offsets are initially set up, the system automatically assigns them to each cutting cycle and replicates them as needed for multiple workpiece instances. The automatic link generator considers the chosen work offsets for optimized positioning moves; the work offsets are also visualized during the simulation and validated during the verification step, taken into consideration during collision detection, and output in the G-code program.

Automatic Link Generator

In the world of production machining, ESPRIT’s automatic link generator is a valuable tool that saves programming time and gets the most out of the machine. By automatically understanding the clearance needed to navigate a tombstone, how to position around complex workholding, managing 4th- and 5th-axis positioning, and determining clearances needed for difficult in-cut repositioning, the link generator speeds programming and reduces cycle times. With the ability to optimize retracts, the link generator allows larger parts to be machined on smaller envelope CNCs, making a big difference to a shop’s bottom line.

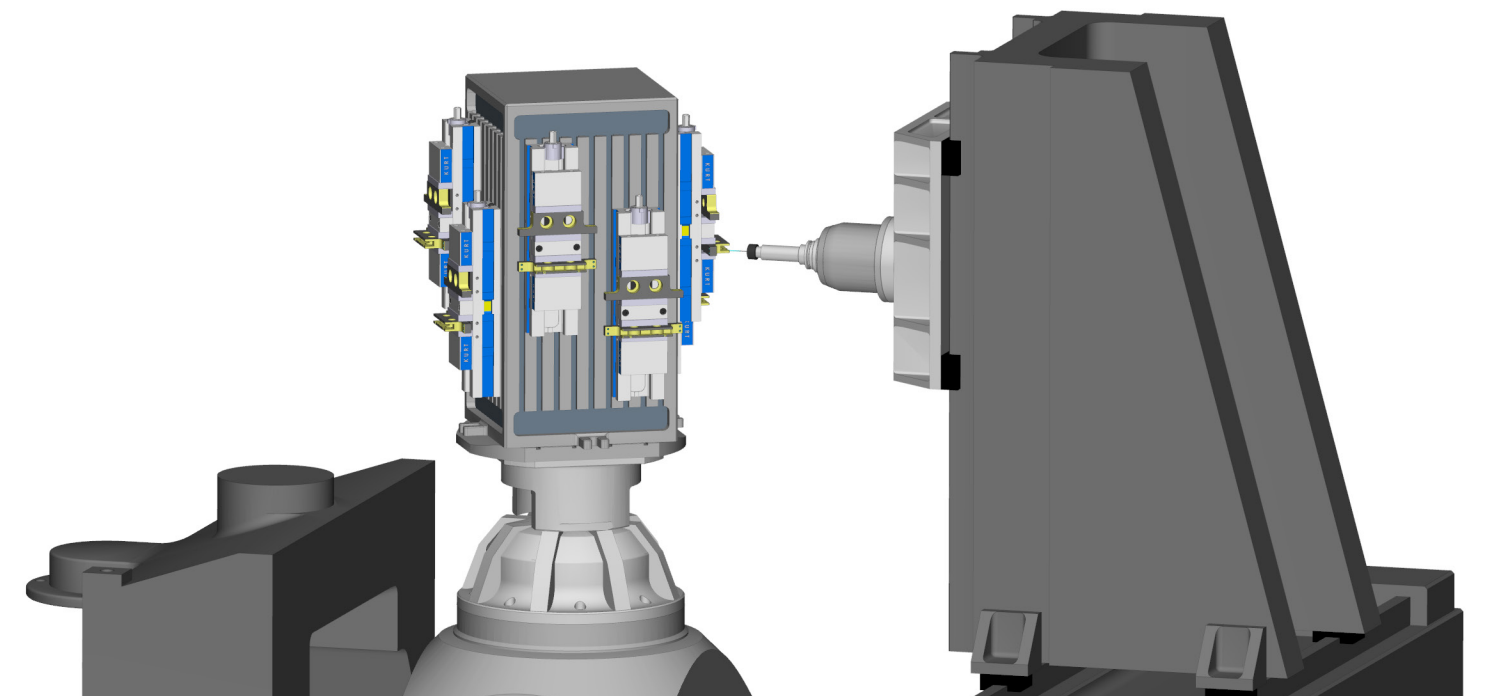

Production Machining



SolidMill

- Traditional 2.5-axis milling, ProfitMilling, plus
- C-axis index and rotary milling
- A-axis, 3+1, index milling
- B-axis, 3+2, index milling
- 3rd rotary axis, 3+3, index milling

SolidTurn

- Traditional 2-axis turning cycles inc. ProfitTurning

FreeForm 3-axis, 4-axis, or 5-axis

- Simultaneous multi-axis milling

Collinear Axes

- Add-on to support programmable collinear axis

Probing

- 3+2 Probing Cycles for any combination of CNC machine, control and touch probe manufacturer

Report Generator

- Shop floor reports that provide information about the machine, tooling, and machining operations

DP Technology Corp.

1150 Avenida Acaso
Camarillo, CA 93012 USA
805 388 6000

espritam.com

05/10/2019

Copyright © 2019 DP Technology Corp. All rights reserved.

High-Performance CNC Programming

Using the ESPRIT Digital Machine - Machine skin models, controller emulators, machine parameters, and post processors, ESPRIT delivers powerful programming, accurate simulation, and edit-free, machine-optimized G-code. The ESPRIT CAM system is backed by world-class technical support to get the job started quickly and to keep it running at top efficiency